

freeway

M205

Weights and dimensions

| | |
|---------------------------|--------------------|
| SWL | : 205 kg |
| Unit weight | : 40 kg |
| A (height) | : 1,340 – 2,010 mm |
| B (length) | : 1,235 mm |
| C (internal width) | : 500 – 1,100 mm |
| D (external width) | : 620 – 1,150mm |
| E (ground clearance) | : 15 mm |
| F (under bed clearance) | : 100 mm |
| G (Carry bar height) | : 380 – 1,750 mm |
| Carry bar width | : 620 mm |
| Turning circle | : 1,010 mm |
| Castor size (front, back) | : 75, 100 mm |

Details

| | |
|----------------------|---------------------------------|
| Product code | : 1301MH-FW-M205 |
| Drawing number | : 123300 |
| GS1 code | : 5056408920117 |
| Warranty | : 3 years |
| Sling connection | : Looped |
| Lift | : Electric (LA44 – 10 kN) |
| Leg opening | : Electric (LA23 – 2.5 kN) |
| Duty cycle | : 15% use, 85% rest |
| Battery | : 24 V SLA, 2.9 Ah |
| Charging time | : 8 hours |
| Lifts per charge | : 30 |
| IP rating (controls) | : IPX4 |
| IP rating (battery) | : IPX5 |
| Material | : Powdercoated steel, vinyl PVC |

Standards

ISO 10535:2006
 IEC 62366-1:2015
 EN ISO 15223-1:2016
 IEC 60601-1:2012
 IEC 60601-2:2014

This product is CE marked and complies with EU MDR 2017/745

Contact

Unit 4 Jubilee Way
 Grange Moor
 Wakefield
 United Kingdom
 WF4 4TD

+44 (0)1924 840100
 info@prismmedical.co.uk

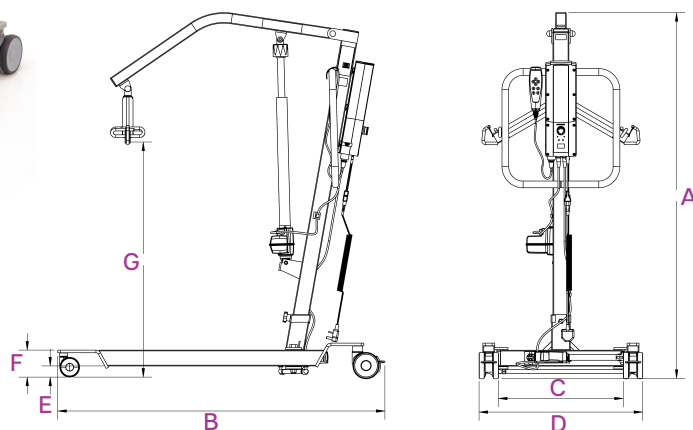

M205 (QRS)

Weights and dimensions

| | |
|---------------------------|--------------------|
| SWL | : 205 kg |
| Unit weight | : 40 kg |
| Carry bar weight | : 2 kg |
| A (height) | : 1,340 – 2,010 mm |
| B (length) | : 1,235 mm |
| C (internal width) | : 500 – 1,100 mm |
| D (external width) | : 620 – 1,150mm |
| E (ground clearance) | : 15 mm |
| F (under bed clearance) | : 100 mm |
| G (Carry bar height) | : 380 – 1,750 mm |
| Carry bar width | : 615 mm |
| Turning circle | : 1,010 mm |
| Castor size (front, back) | : 75, 100 mm |

Details

| | |
|----------------------|-------------------------------|
| Product code | : 1301MH-FW-M205Q |
| Drawing number | : 123301 |
| GS1 code | : 5056408924368 |
| Warranty | : 3 years |
| Sling connection | : Looped |
| Lift | : Electric (LA44 – 10 kN) |
| Leg opening | : Electric (LA23 – 2.5 kN) |
| Duty cycle | : 15% use, 85% rest |
| Battery | : 24 V SLA, 2.9 Ah |
| Charging time | : 8 hours |
| Lifts per charge | : 30 |
| IP rating (controls) | : IPX4 |
| IP rating (battery) | : IPX5 |
| Material | : Powdercoated steel, PU foam |

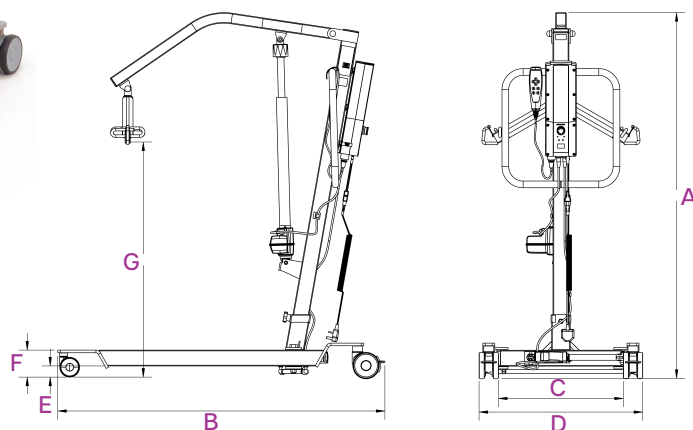

Standards

ISO 10535:2006
 IEC 62366-1:2015
 EN ISO 15223-1:2016
 IEC 60601-1:2012
 IEC 60601-2:2014

This product is CE marked and complies with EU MDR 2017/745

Contact

Unit 4 Jubilee Way
 Grange Moor
 Wakefield
 United Kingdom
 WF4 4TD

+44 (0)1924 840100
 info@prismmedical.co.uk

